

INSTRUCTIONS FOR TRUE-RATE 550, 660 and 880 BATTERY CHARGER
"UNPACKING & ASSEMBLY"

When unpacking the Battery Charger, examine the unit for possible shipping damage. In case of damage, contact the delivering carrier and file a damage claim immediately. Record the serial number and refer to this number during any correspondence with the factory, including parts and repairs. Fasten handle, front leg, axle and wheels with the provided hardware. See parts pictorial and parts list for details.

"INSTALLATION"

Place your Battery Charger in a dry convenient area for access ease. Do not expose to rain. The location should also be near proper wall AC receptacle for ease of plug in. Check your power supply that it is of adequate rating or voltage-ampereage, frequency (Hertz Cycles) for the specification markings on the charger. Be sure the power supply meets National Electrical Code and related local code. The safety ground circuit must be properly connected and the safety ground pin must not be removed from the cord set. The cable provided for this outlet will be found at the rear of the unit. Do not charge batteries in a closed room or space. Provide adequate ventilation for the hydrogen gas.

"ACCESSORIES"

Output Cable & Clamps--The output cables are of the extra flexible and extra heavy insulated welding cable quality. These cables are 8 feet long. The heavy duty battery charger clamps are rated as 100 Amps, and assure a firm grip on the battery posts. The clamps are color coded for the correct polarity, red for Positive (+) black or green for Negative (-).

SAFETY PRECAUTIONS

"OPERATION"

Be sure the CHARGE RATE selector switch is in the "OFF" position. Plug the cable, found at the rear of the unit, into the wall receptacle. Connect the red clamp to the Positive post (+) of the battery being serviced and the green or black clamp to the Negative post (-). Rotate the CHARGE RATE selector switch to required voltage range and desired charge rate. Set the TIMER to the desired time needed for the charging operation. DO NOT operate the charger when the Ammeter needle is pointing higher than maximum rating of charger or in red area on color coded meters. This condition is declared unsafe for operation because the charge is too high. Place a low charge on the battery for 4-5 minutes to warm it up. This warming up of the battery is important if the battery is low (or cold in winter). The warming-up period is followed by the fast charge, and this procedure will prolong the life of the battery. You will receive long and dependable service if you follow these directions.

The Timer in this unit is an ELECTRIC Motor driven device. To set time, turn knob clockwise to desired time rate. When the TIMER has been set and the CHARGE RATE selector switch has been rotated to the desired position, and the unit does not function, one or more of the following operations have not been performed:

1. The correct polarity has not been accomplished.
2. The TIMER has not been set.
3. The CHARGE RATE selector switch has not been moved from the "OFF" position, or,
4. A broken connection within the battery resulting with the battery being unsuitable for use.
5. Battery is completely DEAD.

As mentioned previously, the CHARGE RATE selector switch must be at the "OFF" position before the clamps are removed from the posts. The reason being that sparks will appear if the switch is not turned off, thereby allowing the possibility of igniting the gases which arise from the electrolyte in the battery being charged.

"BATTERY BOOSTING POWER"

1. This charger can be used for start boosting after the battery has received a preliminary 10 minute charge. Use the FAST position as a start booster for engine cranking.
2. When engine starts, turn SELECTOR SWITCH immediately to "OFF" position. Remove clips (one at a time).

CAUTION: This charger provides very high starting current. Excessive cranking can damage the starter system. Do not crank starter over 15 seconds. If engine does not start, allow charger to again charge battery for 5-10 minutes prior to cranking.

NOTE: This unit is built with a SAFETY BREAKER in the AC-LINE, as well with THERMAL OVER-LOAD PROTECTOR in the DC-LINE. If during cranking the Breaker and Thermal-Overload-Protectors trip, the circuits will open. When unit has cooled down to a safe level the DC-Overload Protector will close itself again. On the AC-Safety Breaker push the reset button in to close the AC Line. Now normal operation can continue.

These devices are there for the protection of your vehicle against overload and also protect the charger and its components against overheating.

SLOW CHARGING - MULTIPLE BATTERIES

For slow charging two or more batteries; they must be connected in parallel-POSITIVE post to POSITIVE post, and NEGATIVE post to NEGATIVE post. (See illustration)

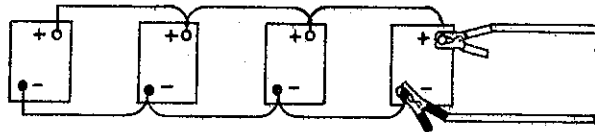

CAUTION: Do not connect batteries with unlike voltages.

- a. Connect RED clip to positive post of battery.
- b. Connect BLACK or GREEN clip to negative post of battery.
- c. Turn Time Control to desired time setting. Use "HOLD" position for charging at SLOW setting only, because the charger will not turn off automatically while Time Control is in "HOLD" Position.
- d. Depending on the number of batteries to be charged, adjust Selector Switch to proper position as shown on chart.

Selector Switch Setting	SLOW	FAST
Maximum Number of Batteries On 50 AMP Chargers	2	5
On 60 AMP Chargers	2	6
On 80 AMP Chargers	4	8

When service is required, consult Electric Schematic prior to dismounting of any component or disconnecting any wire connections, (Particular from the electric motor driven timer, switch, etc.).

The SHUNT in the Positive Output Line is of special alloy and precision calibrated to match the output current & the D. C. Ammeter. DO NOT attempt to replace with any other material.

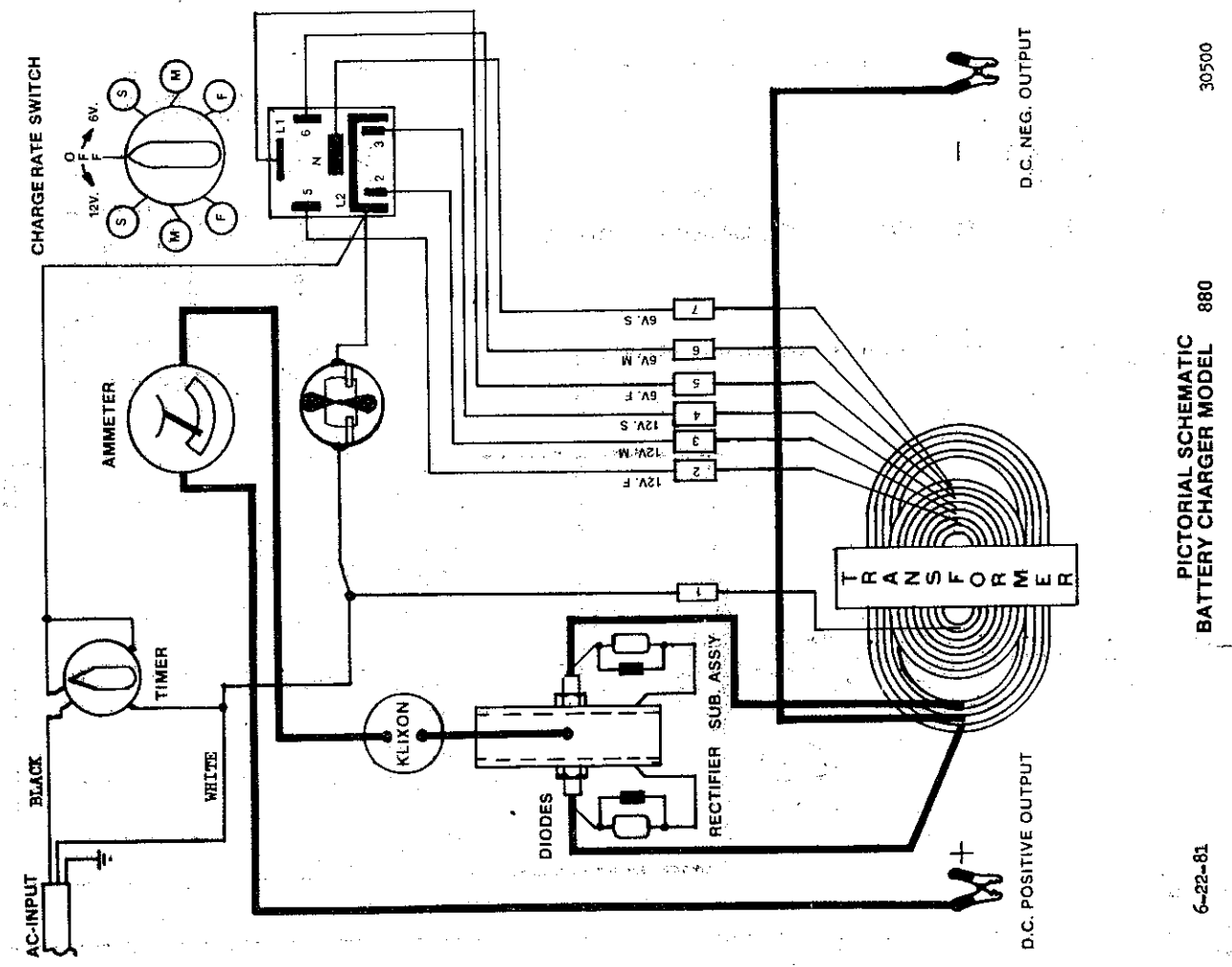
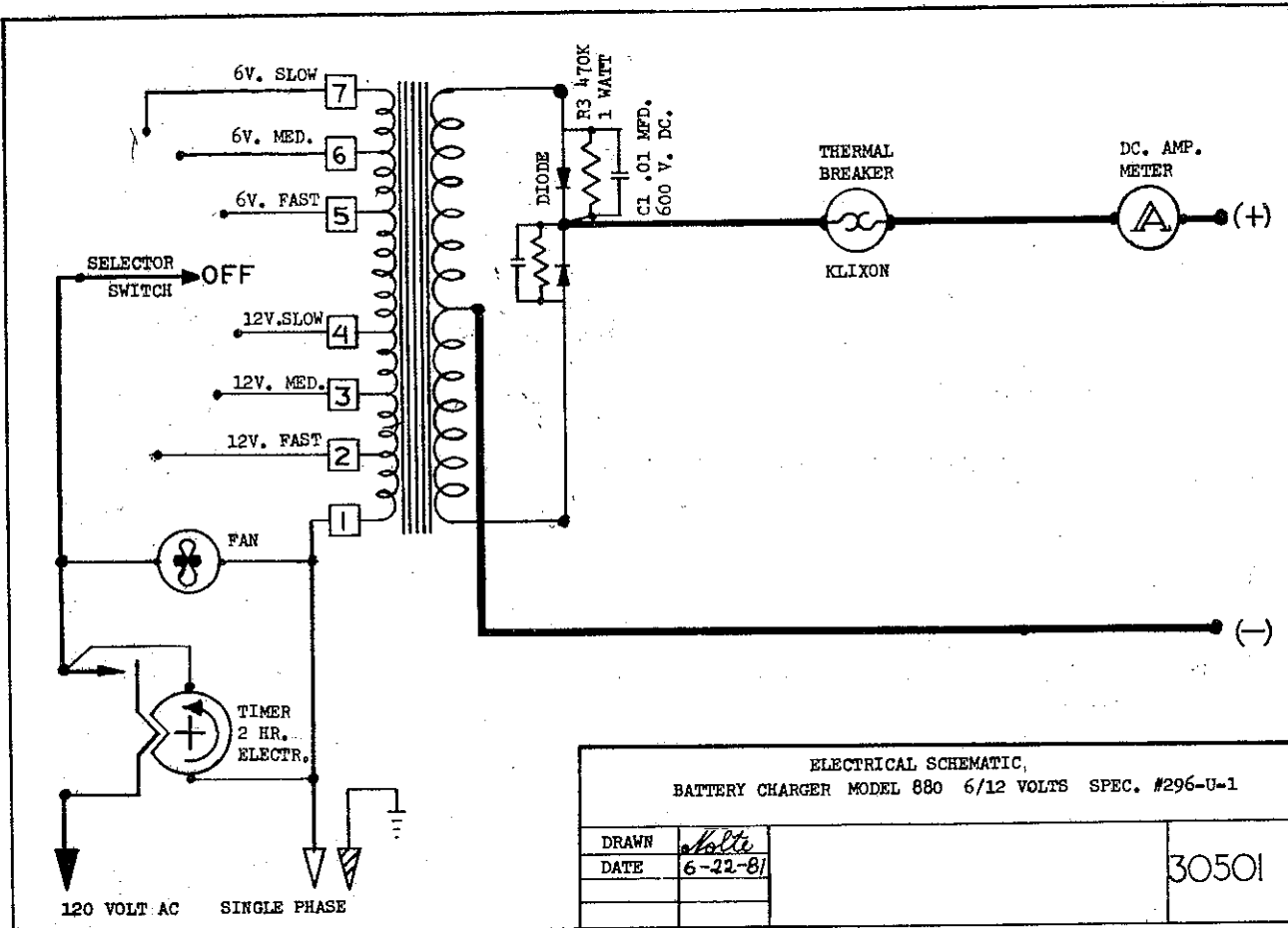

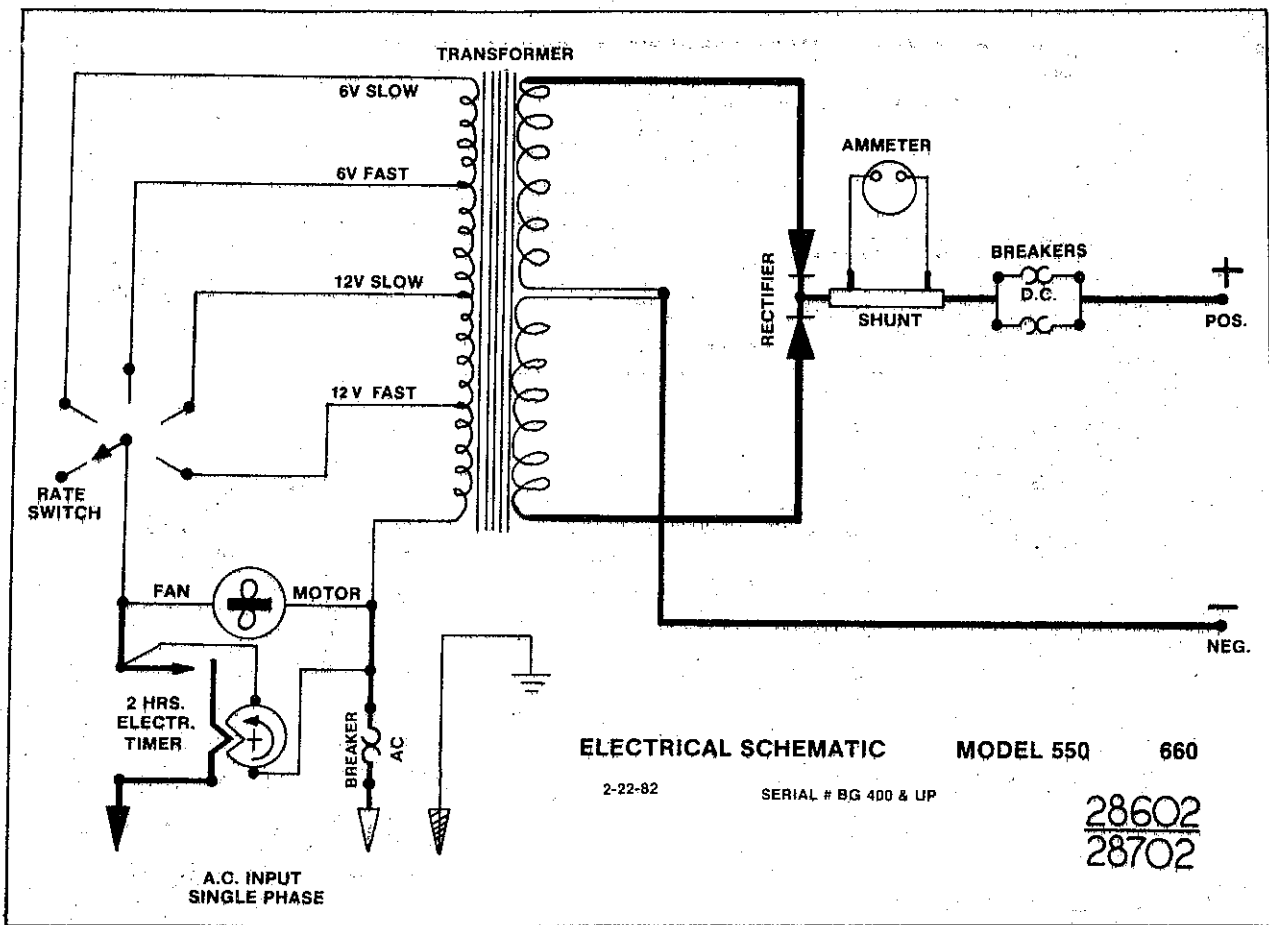

- A.) So as not to scuff the top of the unit, place charger upside down on a soft, clean surface.
- B.) Attach a pushnut to one end of axle, and slide one wheel and then one spacer on the axle.
- C.) Slide front thru axle tabs and install spacer, wheel and pushnut on other end.
- D.) Fasten front leg as shown with 2 Mach. Screws.
- E.) Set unit right side up and attach handle with sheet metal screws as shown.

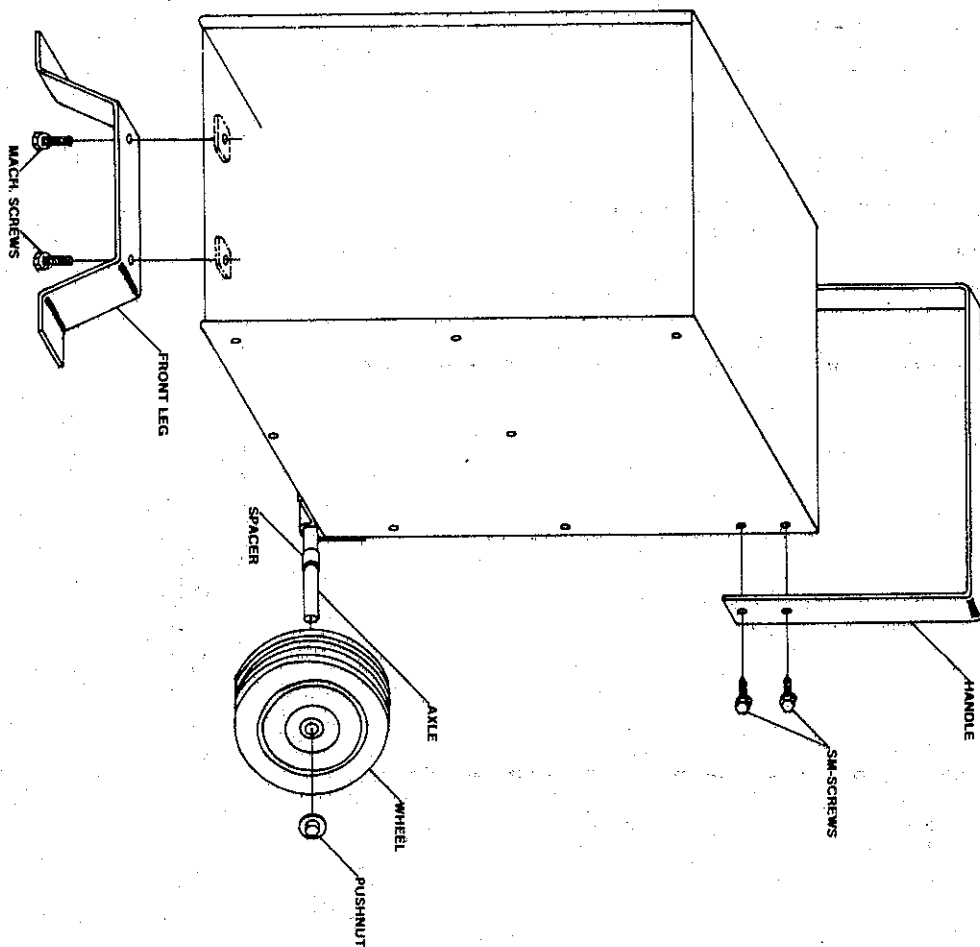

PARTS LIST BATTERY CHARGER MODEL 550, 660, 880

Index No.	Part or Cat. No.	SERIAL # BJ 400 & UP Nomenclature	550	660	880
1a	28655 or 31150	Transformer Ass'y Spec. # 285-U-1 (120V. 60 Hz.) Transformer Ass'y Spec. # 301-U-2 (220V. 50 Hz.)	1 1		
1b	28750 or 31250	Transformer Ass'y Spec. # 278-U-1 (120V. 60 Hz.) Transformer Ass'y Spec. # 302-U-2 (220V. 50 Hz.)		1 1	
1c	30550 or 31350 or 31375	Transformer Ass'y Spec. # 296-U-1 (120V. 60 Hz.) Transformer Ass'y Spec. # 303-U-2 (220V. 50 Hz.) Transformer Ass'y Spec. # 304-U-3 (230V. 60 Hz.)			1 1 1
2	151-5011	Blade, Fan 6-5/8" Dia. (CCW) (50416-0)	1	1	1
3a	50415-0	Motor, Fan, H.D., 115V. AC 60 Hz. (W. bracket & clips)	1	1	1
3b	or 151-5016	Motor, Fan, H. D., 220V. AC 50 Hz. (w. bracket & clips)	1	1	1
4	151-7336 151-7337 151-7305	Switch, 6/12 Volt Charge Rate Selector w. Knob Switch, 6/12 Volt Charge Rate Selector w. Knob Switch 6/12 Volt Charge Rate Selector w. Knob	1	1	1
5	151-0328 30519	Ammeter, DC (2" rd. Case) Serial #AK 024 & up Ammeter, DC (2" Rd. Case) 100/125A.	1	1	1
6	28731 28631	Shunt Shunt	1	1	
7a	<u>148-7804</u>	Timer, Elect., 2 Hr. (w. Knob) 120V. 60 Hz. ✓	1	1	1
7b	or 148-7805	Timer, Elect., 2 Hr. (w. Knob) 220V. 50 Hz.	1	1	1
8	151-0612	Breakers, Thermal-Overload - Protector (45 AMP ea)	2	2	2
9	153-6641	Rectifier, Selenium. F.W. -Center Tap <i>18.36</i>	1	1	<i>880</i>
9a	25175	Rectifier Ass'y F.W. Center Tap (w. Silicon Diodes)			1
9b	153-1510	Diodes, Straight Polarity (#70-H-10) in Rect. Ass'y			2 <i>5.76/8.24</i>
10	28638 25138	Negative Output Cable Ass'y (w. Clamp) Negative Output Cable Ass'y (w. Clamp)	1	1	1
11	54710 54722	Clamp, Negative (Black 7026) Clamp, Negative (Black 67020)	1	1	1
12	28637 25137	Positive Output Cable Ass'y (w. Clamp) Positive Output Cable Ass'y (w. Clamp)	1	1	1
13	54711 54722P	Clamp, Positive (Red 7025) Clamp, Positive (Red 67120)	1	1	1
14	173-1609 173-1409	Cable, Input 16-3 x 9', for 120V. 60 Hz. Unit w. Plug Cable, Input 14-3 x 9', for 120V. 60 Hz. Unit w. Plug	1	1	1
15	28711 30511	Front Panel (for Model 660) Front Panel (for 880)		1	1
16	25110	Case Sides, w. Bottom Panel		1	1
17	28620	Case, Front-Bottom & Rear w. Shelf	1		
18	25113	Top		1	1
19	28618	Case, Top & Sides	1		
20	24923 28623	Front Leg Front Leg	1	2	2
21	24917 28621	Axle Axle	1	1	1
22	148-8406	Wheel, 5-1/2" Dia.	2	2	2
23	28625	Spacer (for wheels)	2	2	2
24	135-7504	Cap, Axle	2	2	2
25	24916 28624	Handle Handle	1	1	1
26	151-0615	Breaker (Reset) AC, 15 Amp	1	1	