

# 242 MIG SET-UP CHART

MATERIAL (Wire)	GAS	WIRE Ø	MATERIAL THICKNESS											
			22 Gauge .0315" (.8 mm)		18 Gauge .0472" (1.2 mm)		16 Gauge .063" (1.6 mm)		1/8" (3 mm)		3/16" (4.5 mm)		1/4" (6.4 mm)	
Regulation Knob			Voltage Setting	Wire Feed Setting	Voltage Setting	Wire Feed Setting	Voltage Setting	Wire Feed Setting	Voltage Setting	Wire Feed Setting	Voltage Setting	Wire Feed Setting	Voltage Setting	Wire Feed Setting
Mild Steel	Mix 75% Ar 25% CO <sub>2</sub>	.023" (0.6 mm)	21.3	220	24.3	300	28.4	450	31.0	650	34.0	700	37.7	950
		.030" (0.8 mm)	21.3	160	24.3	220	28.4	300	31.0	500	34.0	750	42.4	1000
		.035" (0.9 mm)	21.3	150	24.3	200	28.4	250	34.0	400	37.7	500	48.3	700
	100% CO <sub>2</sub>	.023" (0.6 mm)	21.3	150	24.3	220	28.4	400	31.0	500	34.0	800	37.7	950
		.030" (0.8 mm)	-	-	24.3	150	28.4	250	34.0	500	34.0	580	42.4	900
		.035" (0.9 mm)	-	-	24.3	150	28.4	200	34.0	380	37.7	450	48.3	700
Flux Core Wire (No Gas)	.035" (0.9 mm)	21.3	150	22.7	250	24.3	300	28.4	400	34.0	500	42.4	800	
	.045" (1.2 mm)	-	-	22.7	120	24.3	150	28.4	180	34.0	250	42.4	400	
Stainless Steel	Solid Wire 100% Argon	.030" (0.8 mm)	-	-	22.7	180	26.2	400	31.0	480	37.7	650	42.4	900
		.035" (0.9 mm)	-	-	-	-	26.2	250	34.0	400	37.7	450	42.4	600
Aluminum ER4043/ER5356	Solid Wire 100% Argon	.035" (0.9 mm)	-	-	-	-	21.3	300	26.2	550	31.0	700	37.7	750
		.045" (1.2 mm)	-	-	-	-	21.3	250	28.4	500	31.0	600	37.7	650
Aluminum w/spool gun ER4043/ER5356	Solid Wire 100% Argon	.035" (0.9 mm)	-	-	22.7	5.5	24.3	5.7	31.0	6.5	34.0	6.8	-	-

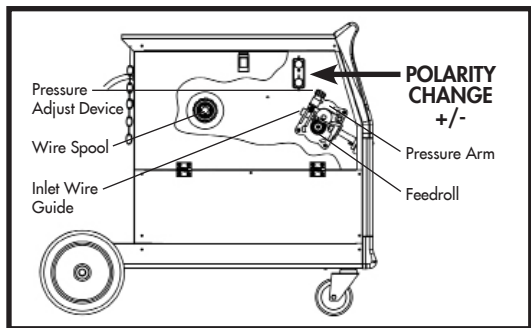

### Arc Voltage Control

This control sets the arc welding voltage. It is proportional to the amount of heat in the arc.

Voltage settings are approximate at no load.

### Wire Speed Control

This sets the wire feed speed (WFS) of the electrode wire through the MIG gun.

WFS ranges 0-950 IPM

WFS arc approximate at no load

### Spool Gun Control